

Tradeshow Booth Setup Instructions

ANY QUESTIONS OR CONCERNS, CALL Debra Salley on CELL at 720-289-4541.

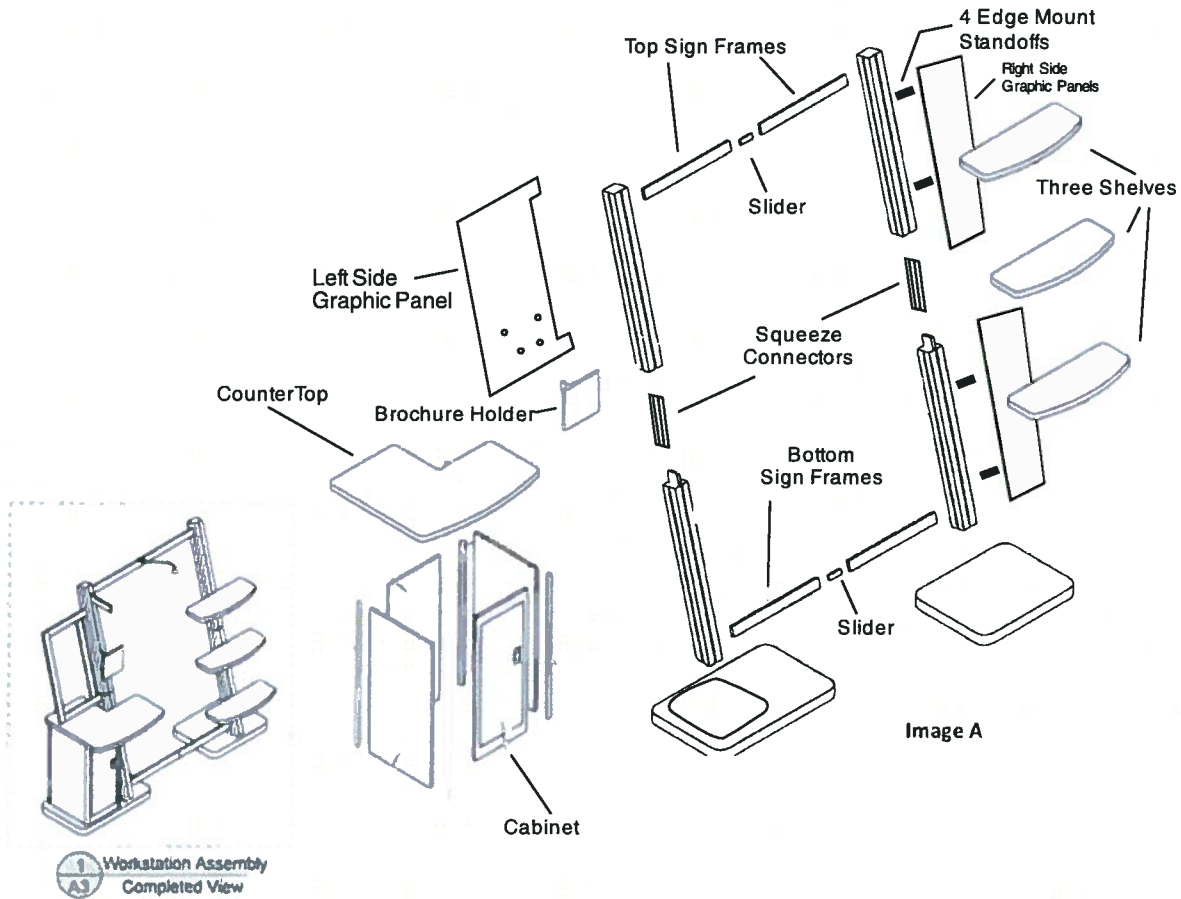

In the Container, there are three areas where you will find each of the items – left, center and right.

Below are the locations of each of the parts you will need for booth assembly.

Left Console:

- Tool Kit
- Fabric Graphic
- Shelves
- Cabinet Panels
- Left Side Graphic Panel
- Right Side Graphic Panels (2 tapered panels)
- Epilog Laser Sign
- Made in the USA Sign



Right Console:

- Lights
- Took KIT
- Top and Bottom Frame for both Fabric graphics and Rigid Epilog Laser Sign
- Step Stool
- TV
- 4 Pillars (Upper 1 and 2, Lower 1 and 2)

Center Console:

- Hardware Cardboard Box w/Brackets, Squeeze Connectors, Shelf Supports
- Cabinet Corners
- 2 Base Plates
- Counter Top



Setup in this order, All instructions below.

1. Setup the Frame
2. Attach the lights
3. Attach the rigid Graphic Panels to left and right of booth
4. Add the EPILOG LASER RIGID sign frame and graphics across frame (Instructions not included, call)
5. Build an attach cabinet
6. Attach brochure holder
7. Attach Monitor
8. FINALLY, install FABRIC graphic with GLOVES,
9. Attach shelves.

Setting up the Frame

- 1) Set the **Base Plate #1** and the **Base Plate #2** on the ground with the screw holes at the front of the base.

NOTE: Center the frame in the booth! Moving the frame after is completely assembled and standing is hard to do.

- 2) Attach **Lower Pillar #1** to the **Base Plate #1** with the pillar leaning away from the front using the largest screw in the tool kit.
- 3) Attach **Lower Pillar #2** to the **Base Plate #2** again with largest screw in tool kit. You MAY need to also use a washer.
- 4) Place the **Squeeze Connector** half way into the top of **Lower Pillar 1** and **Lower Pillar 2** then place the Upper Pillars on top of the squeeze connector (**Image C**).
- 5) Secure the top and bottom pillars together by using the sliders on the back and side of the pillars. Center the sliders between the pillars and then tighten. You Must do this to provide stability.

On the **Pillar 1 slider** on the side where the cabinet will go, only place one screw above the seam and three below to leave room for signage to be attached.

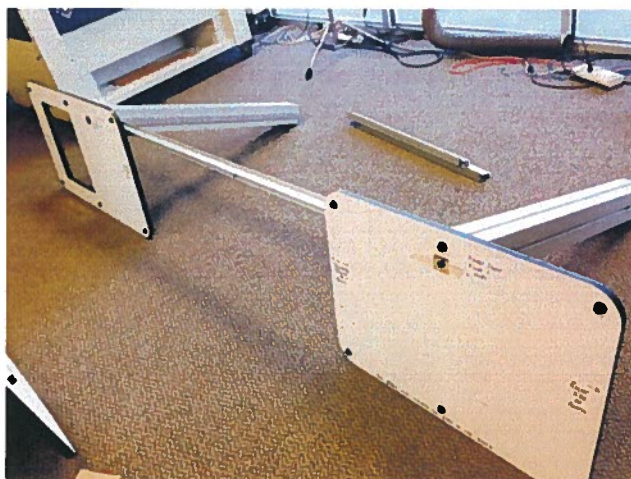

very

Image B

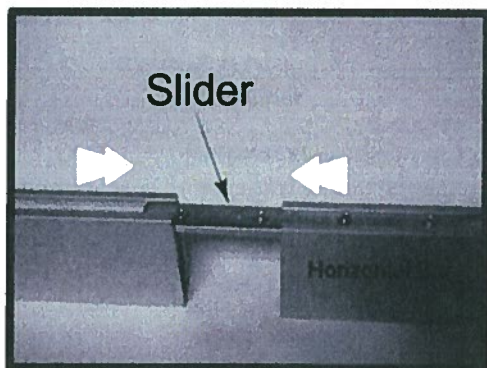

When connecting horizontal and vertical components, move the slider so it is centered over both pieces and secure with the setscrews using a hex wrench.

Image C

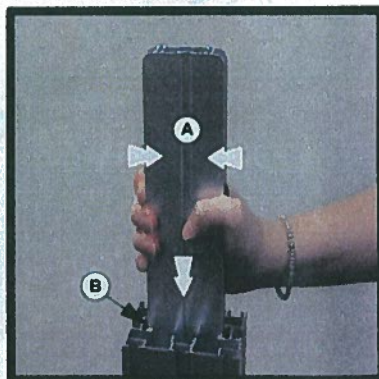

Squeeze the squeeze connector (A) and insert it into the Lower Pillar.

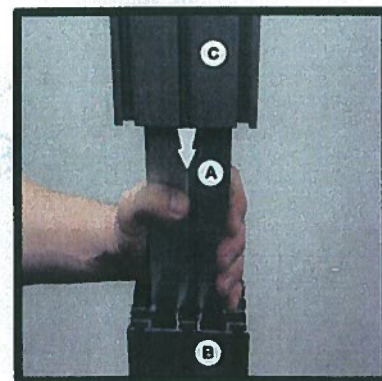

Squeeze the squeeze connector (A) again to attach the Upper Pillar to the Lower Pillar. Adjust and tighten the sliders on the side and back of the Pillars.

- 6) Connect the **Bottom Fabric Sign Frames 1 & 2** bars. Adjust the slider on the bottom of the bars so it spans both bars and then tighten. [Image B](#)
- 7) Attach the **Bottom Fabric Sign Frame 1** to the **Lower Pillar 1** with the silicone track facing up. Turn the cam locks 1/4 turn to secure it to the pillar. Repeat with the **Lower Pillar 2**.
- 8) Connect the **Top Fabric Sign Frames 1&2** pieces with the silicone track facing down. Adjust the slider so it spans both frame pieces and then tighten.
- 9) Attach the **Top Fabric Sign Frames** the **Upper Pillar 1** with the silicone track facing down. Turn the cam locks 1/4 turn to secure it to the pillar. Repeat with **Upper Pillar 2**.
 - Be sure the top of each frame piece lines up to the top of the pillars so the graphic will attach correctly.

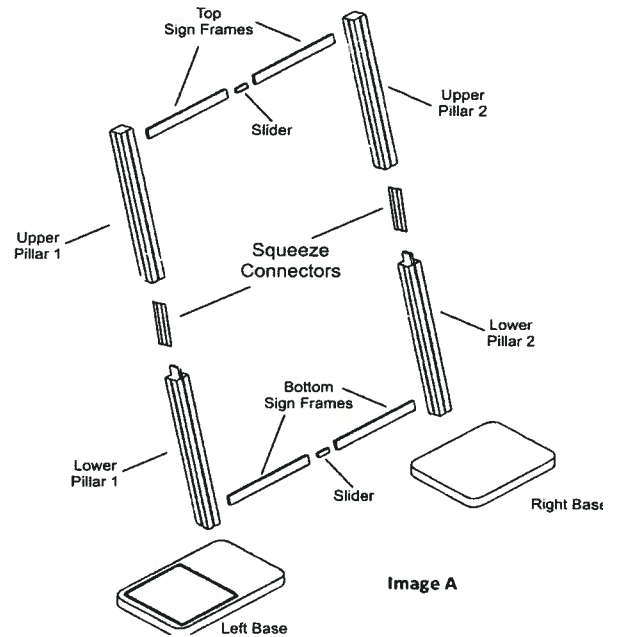

Install Lights

Install the lights onto the **Top Fabric Sign Frame** using the step stool, attach the lights to the top of the booth. Run the cords down the back of the frame, if necessary; tape the cords to the frame to keep out of way.

Install Graphic Panels

- 1) Attach the rectangular graphic panel to the left side of Upper Pillar 1, turning the two cam locks 1/4 turn to attach.
- 2) On the right side of the booth, place four of the standoff edge mounts (Image A) in the track, turning them by hand 1/2 turn to lock in place.
- 3) Place the two right side graphic panels in the standoff mounts and tighten them slightly to hold in place. Image B
- 4) DO NOT USE MADE IN USA SIGN! Image C
- 5) Instead use **RIGID Epilog Laser Graphic**. Attach the **Rigid Frame Wall Connector** left and right to both **Top Pillar 1 and Top pillar 2**, then span **Rigid Frame for Epilog Laser Sign** with Velcro on front across the two connectors and Velcro the **Epilog Laser Sign** onto frame.

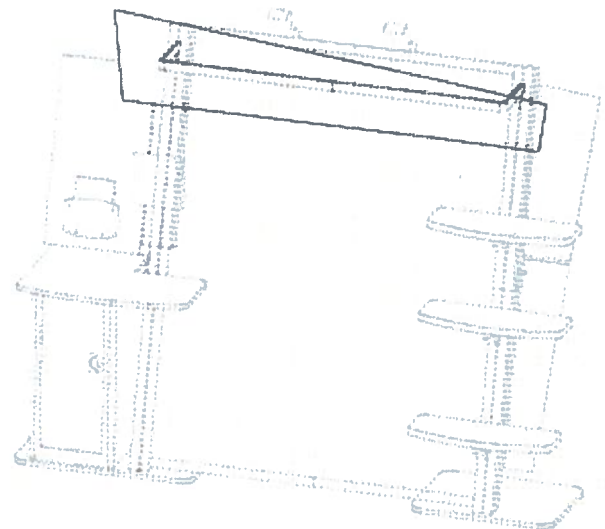
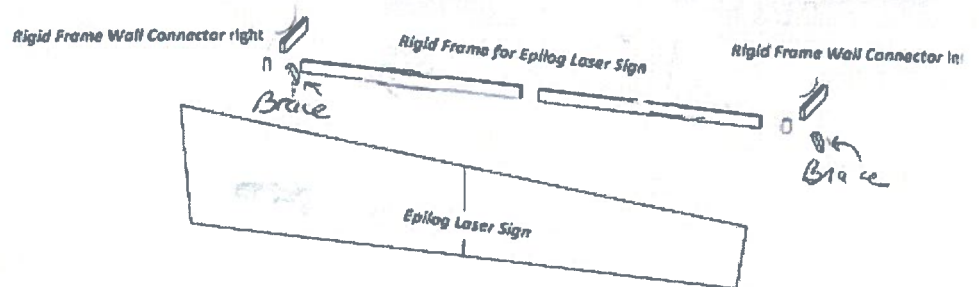
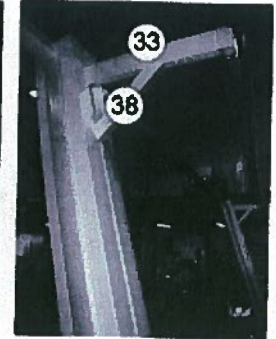

6) Attach brochure holder to side panel using screws and standoffs in the tool kit.



Image A



Image B



Image C

Attach Cabinet Assembly

- 1) Place the front panel at the front of the wood frame on the left base. Attach a corner to the front panel. (Do not slide the corner piece down from the top – place the top of the corner about 2" above the top of panel and then slide down.)
- 2) All corner pieces are identical and can be used in any corner.
- 3) Repeat with each panel and corner as show to the right.
- 4) To install the counter, attach the wall connector on the bottom side of the counter, and attach with cam locks.
- 5) Attach wall connector to the track on the pillar with cam locks.

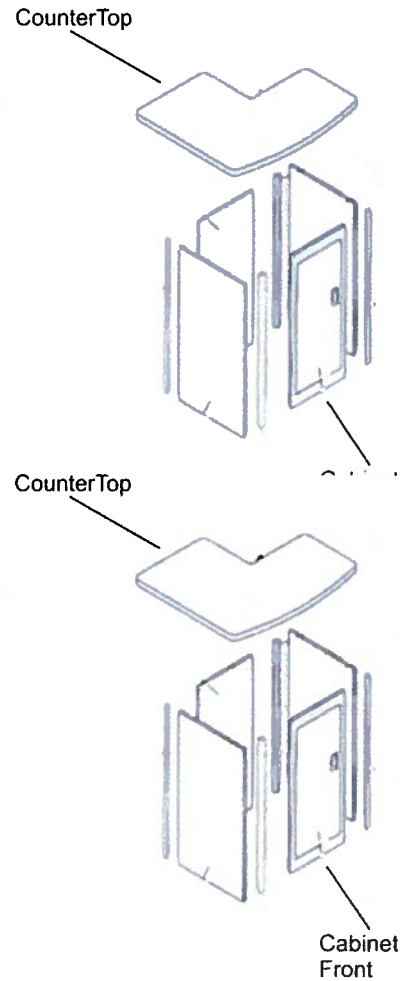

Brochure Holder

1. Assemble the brochure holder to the graphic panel on the left side of the booth.
2. The brochure holder consists of the stand offs and an acrylic front piece.



Monitor

Starting the continuous loop video:

- 1) Attach the monitor connector to the front side of Upper Pillar 1 using cam locks. [Image C and D](#)



Image C



Image D

Attach the TV monitor to the monitor connector and route the cables behind the booth.

Need a new photo here!

Installing Stretch Graphic Sign WAIT, INSTALL STRETCH GRAPHIC LAST!

- 1) **Wear Gloves!** The white fabric will stain, so gloves are provided in the fabric graphics bag.
- 2) Start in the upper left or right corner. Stand on the stool to get the top edge of the graphic into place.
- 3) Make sure all of the silicone tracks are aligned at the corners of the booth. This will make assembly much easier.

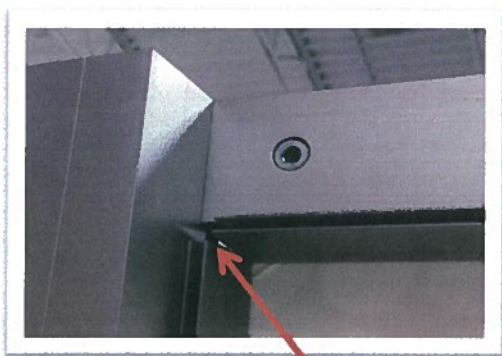

Be sure all silicone tracks are aligned.

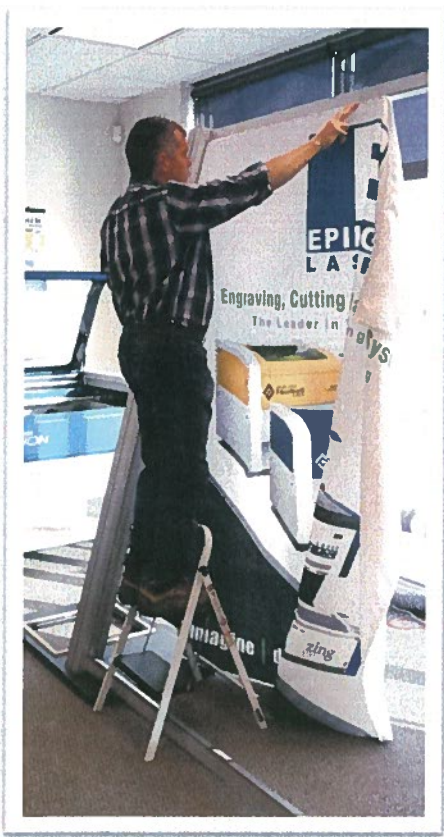

Stand on the stool and insert about 12" of the graphic into the left and top tracks.

Then, insert the graphic along the top bracket all the way to the right edge.

Next, insert the graphic down the sides, and finally along the bottom.

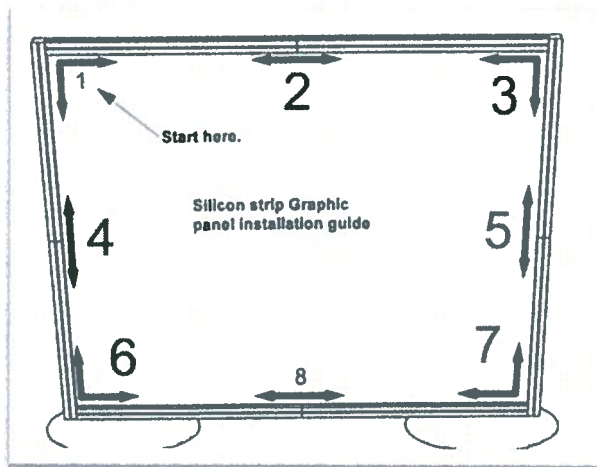

Shelves

- 1) In the Hardware Cardboard Box, remove the three shelf brackets. Attach each bracket to the bottom of a shelf by sliding it into the bracket holder and turning the cam lock 1/4 turn. [Image A](#)
- 2) Place each shelf bracket in the right pillar's track, spacing them evenly. Tighten the cam lock to attach. [Image B](#)

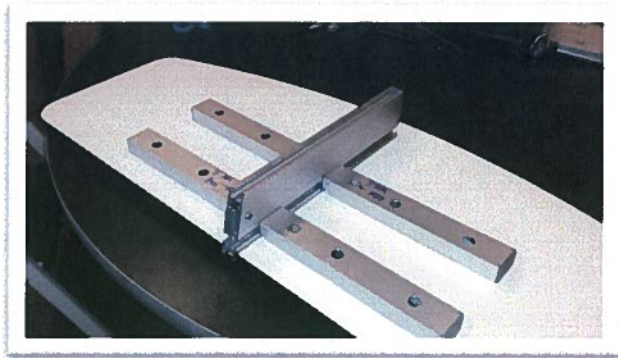

Image A



Image B